

R12/17...L120/11

Version: C SE I1; C SE T1

en Assembly and Operating Instructions

Sun protection drives with locking system

Important information for:

• Fitters / • Electricians / • Users

Please forward accordingly!

These instructions must be kept safe for future reference.

2010 300 601 0d 05/10/2016

Becker-Antriebe GmbH
Friedrich-Ebert-Straße 2-4
35764 Sinn/Germany
www.becker-antriebe.com



BECKER

Table of contents

General	3
Warranty	3
Safety instructions	4
Instructions for the user	4
Instructions for installation and commissioning.....	4
Intended use	6
Assembling and disassembling the plug-in connecting cable.....	6
Assembling the plug-in connecting cable	6
Disassembling the plug-in connecting cable for tubular drives dia. 45 and dia. 58	7
Installation.....	8
Assembling the drive	8
Undoing the mounting pin.....	8
Assembling the drive adapter with drive adapter safety catch.....	8
Assembling the drive adapter with screw connection.....	9
Securing the drive against axial displacement.....	9
Fixing the drive adapter to the barrel dia. 45 and dia. 58	9
Mounting the drive in the tube	9
Setting the limit positions.....	10
Deleting the limit positions using the programming unit.....	12
Information for the electrician	13
Disposal	13
Maintenance	13
Technical data dia. 45	13
Technical data dia. 58	14
What to do if...?.....	15
Sample wiring diagram	16
Declaration of conformity	17

General

These tubular drives are high-quality products with the following features:

- Optimised for sun protection applications with locking system
- Automatic detection of upper limit position
- Automatic detection of lower limit position when the locking system is activated
- Easy to set and delete the limit positions using the programming unit
- Several drives can be operated in parallel
- Compatible with existing drives with electronic limit switching (4-core connecting cable)
- Comprehensive range of the drive manufacturer's control units can be used
- Smooth operation of the system and the drive increases the service life
- For plug-in connecting cable

Please observe these Assembly and Operating Instructions when installing and setting the equipment.



The date of manufacture comes from the first four digits of the serial number.

The numbers 1 and 2 indicate the year and the numbers 3 and 4 indicate the calendar week.

Example: 24th calendar week in 2012

Ser. No.:	1224XXXXX
-----------	-----------

Explanation of pictograms

	CAUTION	CAUTION indicates a hazardous situation which, if not avoided, could result in injury.
	ATTENTION	ATTENTION indicates measures that must be taken to avoid damage to property.
		Denotes user tips and other useful information.

Warranty

Structural modifications and incorrect installation which are not in accordance with these and our other instructions can result in serious injuries, e.g., crushing of limbs. Therefore, structural modifications may only be carried out with our prior approval and strictly in accordance with our instructions, particularly the information contained in these Assembly and Operating Instructions. Any further processing of the products which does not comply with their intended use is not permitted.

The end product manufacturer and fitter have to ensure that all the relevant current statutory, official and, in particular, EMC regulations are adhered to during utilisation of our products, especially with regard to end product manufacture, installation and customer advice.



Safety instructions

The following safety instructions and warnings are intended to avert hazards and to prevent property damage and personal injury.

Instructions for the user

General information

- All work, including maintenance and cleaning, on electrical installations as well as other system parts must always be performed by authorised specialists, in particular qualified electricians.
- Children from the age of 8 years and persons with reduced physical, sensory or mental capabilities or lack of experience and/or knowledge may use these devices, provided they are supervised or have been instructed in the safe use of the device, and have understood the hazards involved. Children must not play with the device.
- Systems have to be checked regularly by authorised specialists for wear and damage.
- Always put damaged systems out of operation immediately until they are repaired by an authorised specialist.
- Do not operate equipment if people or objects are within the danger zone.
- Observe the danger zone of the equipment during operation.
- Stop and disconnect the equipment from the mains power supply when maintenance and cleaning is being performed either on the system itself or in the immediate vicinity of it.
- Ensure that there is adequate clearance (at least 40 cm) between moving parts and adjacent objects.



Caution

Safety instructions for avoiding serious injuries.

- **Crushing or shearing points must be avoided or protected.**

Instructions for installation and commissioning

General information

- Observe the safety instructions in EN 60335-2-97. Please note that this list of safety instructions is not exhaustive, since it would be impossible for the standard to include all sources of danger. For example, the design of the operated product, the way the drive works in the situation it is installed in or even the way the end product is mounted in the end user's place of use cannot be taken into consideration by the drive manufacturer.

If any questions or uncertainties regarding the safety instructions contained in the standard arise, please contact the manufacturer of the part or end product in question.

- All applicable standards and regulations for electrical installation must be complied with.
- All work, including maintenance and cleaning, on electrical installations as well as other system parts must always be performed by authorised specialists, in particular qualified electricians.
- Only use spare parts, tools and accessory devices which have been approved by the drive manufacturer.
Unapproved third-party products or modifications to the system and its accessories represent a risk to your safety and the safety of others. This means that the use of unapproved third-party products, or modifications which have not been agreed with or approved by us, are prohibited. We do not accept liability for damage or injury arising from such actions.
- Position control devices within sight of the driven product, but away from moving parts, at a height of over 1.5 m.
- Permanently mounted control devices must be positioned where they can be seen.
- Rated torque and duty cycle must be suitable for the requirements of the driven product.
Technical data – rated torque and service life can be found on the type plate of the tubular drive.

- Moving parts of drives must be installed at a height of over 2.5 m above floor level or any other surface from which access to the drive is gained.
- To ensure safe operation of the system after commissioning, the limit positions must be correctly set/programmed in.
- Drives with a H05VV-F connecting cable may only be used indoors.
- Drives with a H05RR-F, S05RN-F or 05RN-F connecting cable may be used both indoors and outdoors.
- To connect the drive to the driven part, solely mechanical accessory components made by the drive manufacturer from the current product catalogue may be used. The components must be installed in accordance with the manufacturer's instructions.
- If the drive is used for shading solutions in a specially marked area (e.g. escape routes, hazard zones, safety areas), compliance with all applicable regulations and standards must be ensured.



Caution

Safety instructions for avoiding serious injuries.

- **When electrical or electronic equipment and units are operated, certain components, e.g., the power supply unit, are live. Physical injuries or damage to property can result in the event of unauthorised interventions or failure to heed warnings.**
- **Be careful when touching the tubular drive, as it heats up during operation for technological reasons.**
- **Before installation, shut down all lines and control devices that are not essential for operation.**
- **Crushing or shearing points must be avoided or protected.**
- **When installing the drive, all-pole disconnection from the mains with a contact gap of at least 3 mm per pole must be provided (EN 60335).**
- **If the drive mains connecting cable is damaged, it must be replaced with the same type of mains connecting cable, which is available from the drive manufacturer.**

Attention

Safety instructions for avoiding property damage.

- **Ensure that there is adequate clearance between moving parts and adjacent objects.**
- **The drive must not be carried by the mains connecting cable.**
- **All latching connections and fastening screws on the brackets must be checked to ensure that they are secure.**
- **Ensure that nothing rubs against the tubular drive, such as shading solution attachments, screws, etc.**



Intended use

The type of tubular drive described in these instructions is intended solely for the operation of sun protection systems with locking system. To function properly, these tubular drives need a fixed stop in the upper limit position (retracted sun protection). It may only be used in networked systems if all the individual drives are exactly synchronised and reach the limit positions at the same time.

For roller shutter applications, please use only the types of tubular drive designed for this purpose.

This type of tubular drive is designed for use in single systems (one drive per barrel).

The tubular drive must not be used in potentially explosive areas.

The connecting cable is not suitable for transporting the drive. Always carry the drive by the housing tube.

Other applications, uses and modifications are not permitted in order to protect the safety of the users and others, since these actions can impair the system's safety and carry the risk of personal injury and property damage. The drive manufacturer does not accept liability for damages or injury arising from such actions.

Always observe the information in these instructions when operating or repairing the system. The drive manufacturer does not accept liability for damage or injury resulting from improper usage.

Assembling and disassembling the plug-in connecting cable

Assembling the plug-in connecting cable

Insert the **dead** connecting cable into the drive head until the locating lug clicks into place in the drive. If necessary, use a suitable flathead screwdriver to assist with insertion. Set the screwdriver into one of the two plug grooves provided for this purpose.

Check that the cable is properly engaged.

C+plug

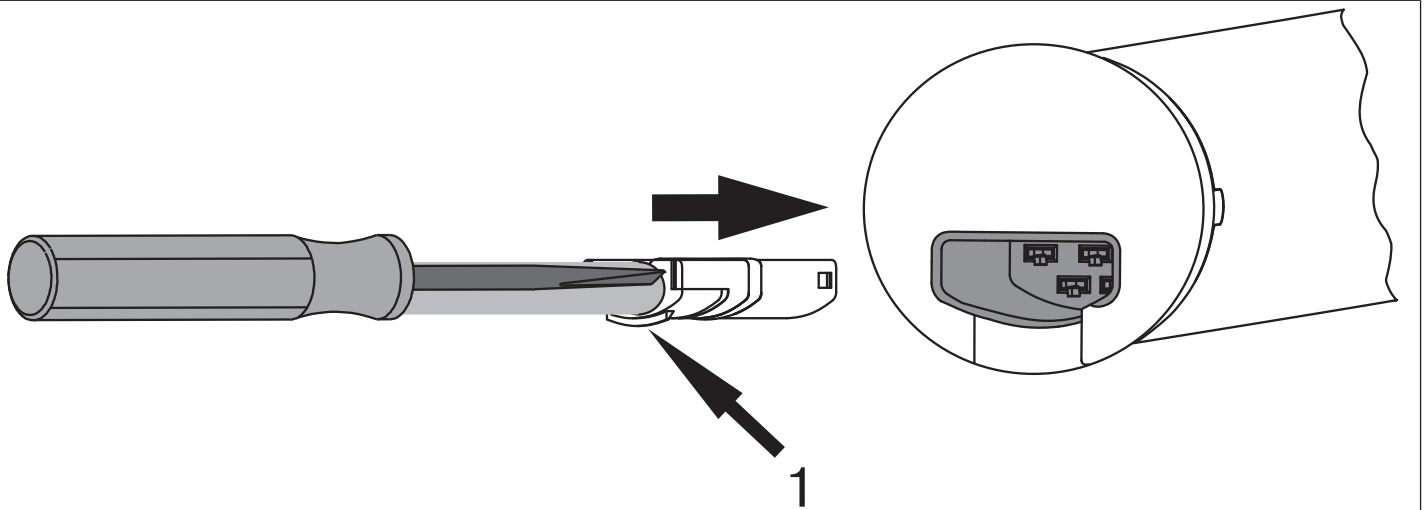

1 = locating lug

Disassembling the plug-in connecting cable for tubular drives dia. 45 and dia. 58



Caution

Prior to disassembly, the power supply to the connecting cable must be disconnected.

Insert a suitable flathead screwdriver right into the recess of the locating latch, so that the latch releases the locating lug from the plug.

Now you can pull out the connecting cable along with the flathead screwdriver.

dia. 45 and dia. 58

C-plug

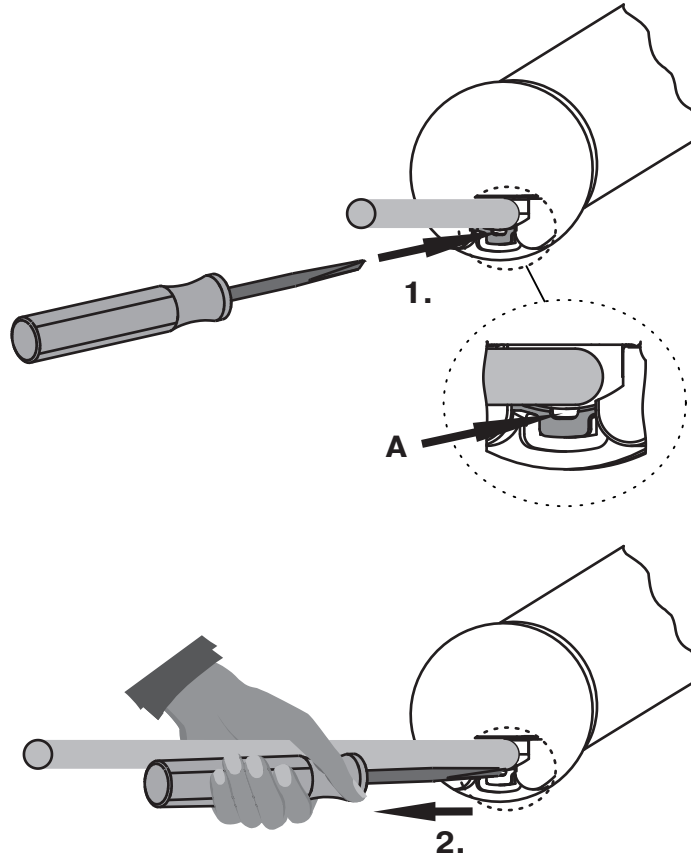

A = locating latch



Installation

Assembling the drive

Attention

To connect the drive to the driven part, solely mechanical accessory components made by the drive manufacturer from the current product catalogue may be used.

Prior to mounting, the fitter must ensure that the masonry and the system being motorised are sufficiently robust (drive torque plus weight of the shading solution).



Caution

Electrical connections may only be carried out by a qualified electrician. Prior to assembly, the power supply must be disconnected and secured. Please give the enclosed connection information to the responsible electrical contractor.

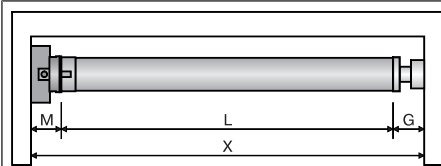

Calculate the space required at the side (M) by measuring the drive head and wall bracket. The clear dimension of the box (X) minus the space required at the side (M) and idler (G) gives the length (L) of the barrel: $L=X-M-G$.

The space required at the side (M) varies depending on the combination of drive and wall bracket.

Then mount the wall bracket and idler. Ensure that the barrel is aligned at right angles to the wall and that sufficient axial play is allowed for the mounted system.

Undoing the mounting pin

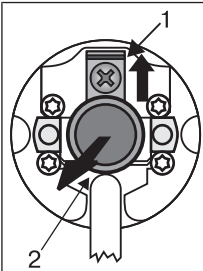

When pushed in, the mounting pin (2) locks automatically. To undo the mounting pin (2), push the tab washer (1) upwards and pull out the mounting pin (2).

Assembling the drive adapter with drive adapter safety catch

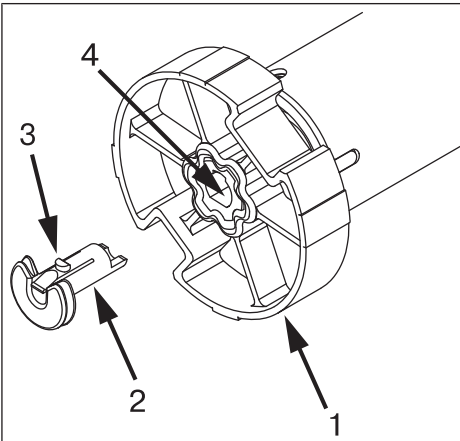

Put the drive adapter (1) onto the drive shaft of the tubular drive. You can see where to insert the safety catch (2) from its shape. When inserting the drive adapter safety catch (2) into the hole (4), make sure that the locking lug (3) engages. You will hear a click. Check that the safety catch is securely in position by pulling on the drive adapter (1).

Assembling the drive adapter with screw connection

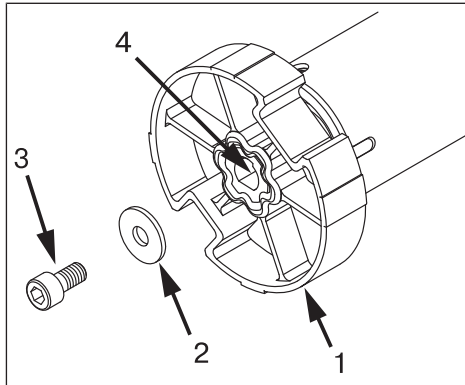

Put the drive adapter (1) onto the drive shaft of the tubular drive. For the assembly, use an M6 x 12 screw (3) with appropriate washer (2) and suitable screw retainer. Threaded hole (4)

Securing the drive against axial displacement

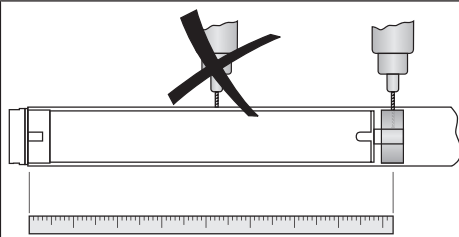

In order to secure the drive against axial displacement, we recommend screwing the drive adapter to the tube.

Attention

When drilling into the barrel, never drill near the tubular drive!

Fixing the drive adapter to the barrel dia. 45 and dia. 58

Size of drive [mm]	Diameter of barrel [mm]	Torque max. [Nm]	Fastening screws for drive adapter (4 pc.)
dia. 45	60 - 70 mm plastic or diecast drive adapter	40	self-tapping screw dia. 4.8 x 9.5 mm
dia. 58	63 - 120 mm diecast drive adapter	120	self-tapping screw dia. 6.3 x 13 mm
dia. 58	85 - 133 mm aluminium drive adapter	120	countersunk screw M8 x 16 mm

We also recommend screwing the idler to the barrel.

Attention

Do not hammer or drop the tubular drive into the barrel!

Mounting the drive in the tube

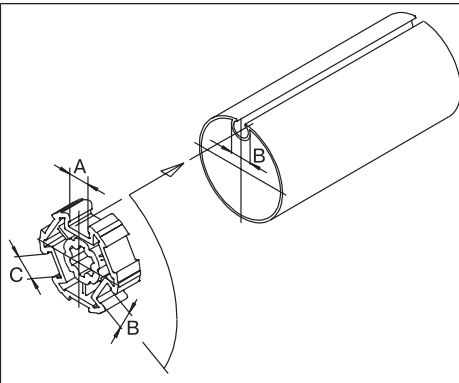

For profile tubes:

In the case of some drive adapters, tolerances of the groove widths in different barrels can be offset by rotating the drive adapter into a different groove recess. These groove recesses have different sizes and allow the drive to fit exactly.



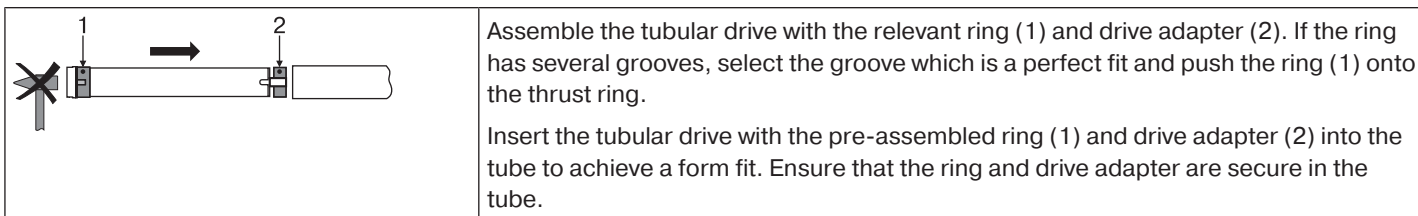
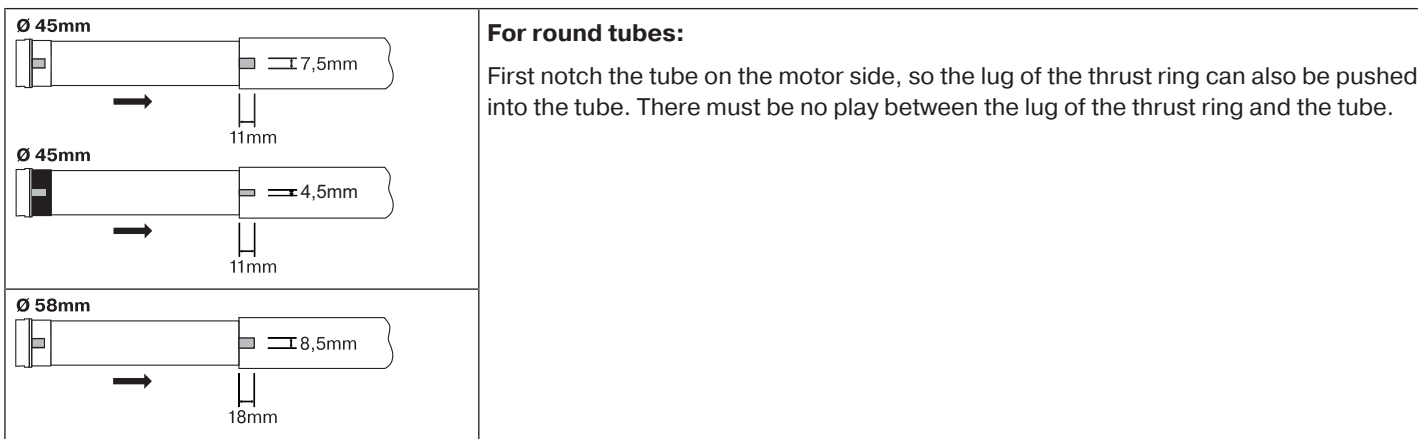

Mount the assembled unit comprising barrel, tubular drive and idler on the box and secure the drive with a split or spring pin according to the type of wall bracket fixing.

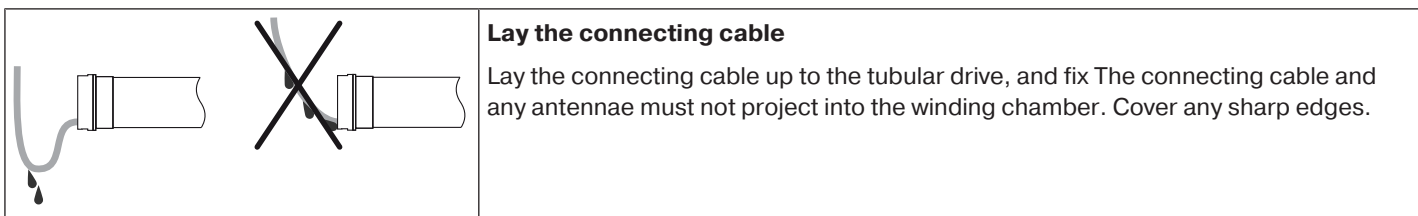

Setting the limit positions

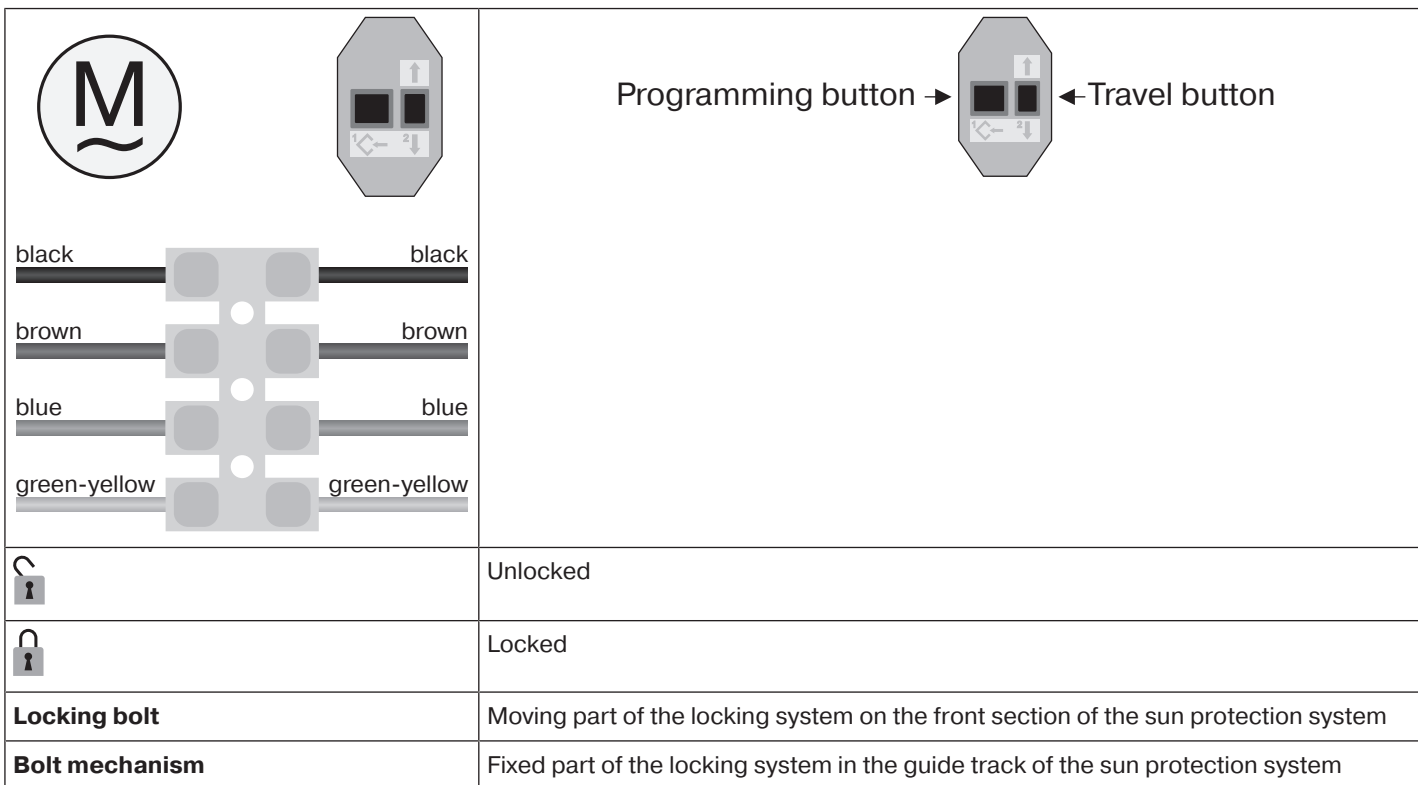

Connect the wires of the tubular drive to those of the same colour in the programming unit (Item No. 4935 200 011 0) and switch on the power supply.

i If the tubular drive switches off prematurely while opening, due to an obstruction, the obstruction can be cleared by closing the screen and removing the obstruction. The upper limit position can be set by opening again.

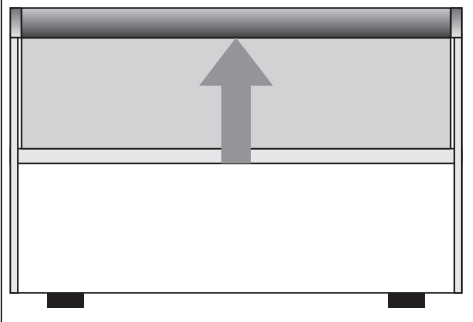
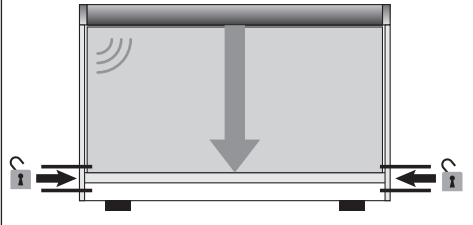
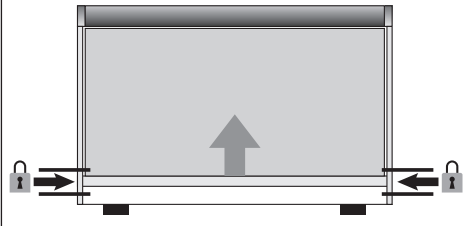
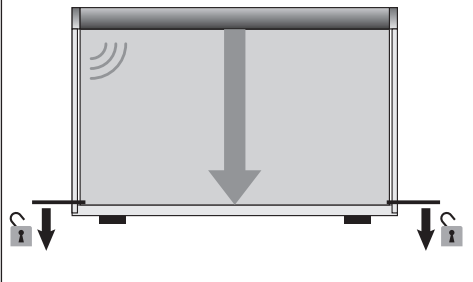
	<p>First, press the travel button to retract to the upper limit position, until the tubular drive switches itself off.</p>
	<p>Run the bolt past the locking point and stop the tubular drive. Then press the programming button.</p> <ul style="list-style-type: none"> ▶ The locking limit position is now saved and the tubular drive makes a "click" sound to confirm.
	<p>Use the travel button to run the bolt in the open direction until it is engaged by the bolt mechanism.</p> <ul style="list-style-type: none"> ▶ The tubular drive switches off automatically.
	<p>Use the travel button to run the bolt in the down direction and disengage it from the bolt mechanism, then stop the tubular drive. Then press the programming button.</p> <ul style="list-style-type: none"> ▶ The unlocking limit position is now saved and the tubular drive makes a "click" sound to confirm. ▶ Limit positioning is now complete. <p>The sun protection system will now lock and unlock automatically in the lower limit position when you close and open it.</p>

Attention

The tubular drives are designed for short-time operation (S2/KB 4 min). An inbuilt thermal protection switch prevents overheating of the tubular drive. During commissioning (long drop distance or long running time), the thermoswitch may trigger. The drive will switch off. After a short cooling-down period, the system is ready for operation again. The drive does not achieve its full duty cycle until it has cooled to ambient temperature. Avoid a situation where the thermal protection switch cuts in repeatedly.

To remove the drive or to clear the internal memory, you will again need the Becker programming unit for drives with electronic limit switching. You can then reset the tubular drive to its factory default settings, for example, in order to:

- - repeat the installation
- - remove the drive
- - set a new limit position
- - operate a defective drive in emergency mode.



Deleting the limit positions using the programming unit

i Connect the wires of the tubular drive to those of the same colour in the programming unit and switch on the power supply.
Please pause for 1 sec after the last drive command before beginning the deletion sequence. Also leave a pause of 1 sec between the individual steps of the deletion sequence.

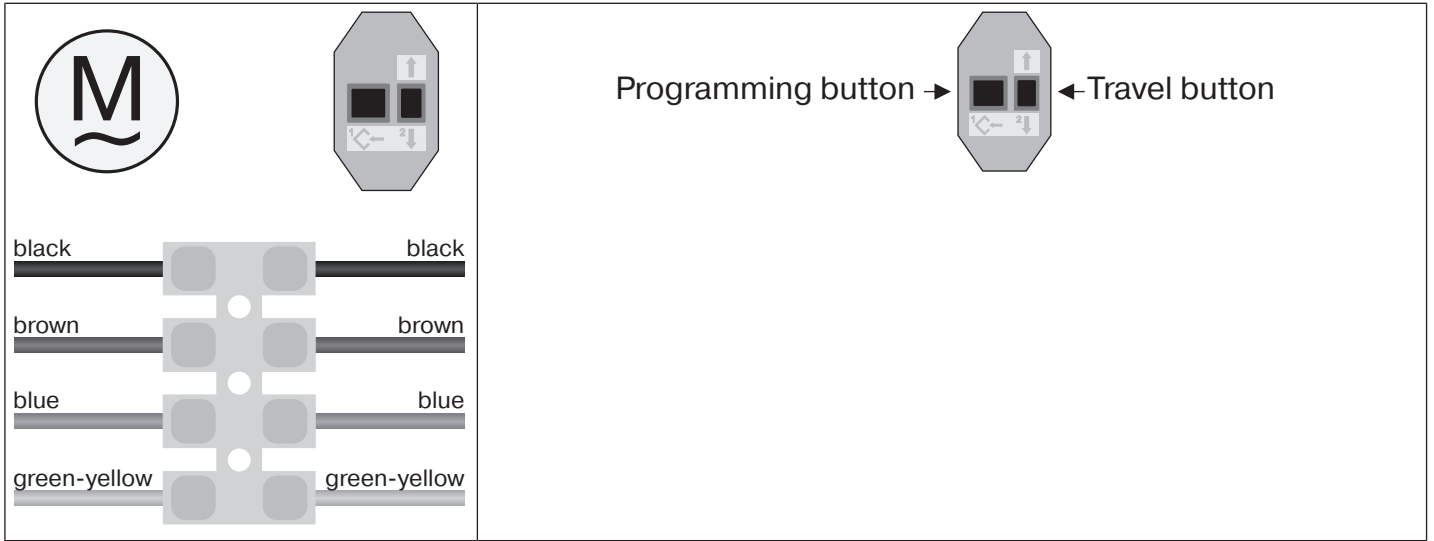

Deleting limit positions during installation

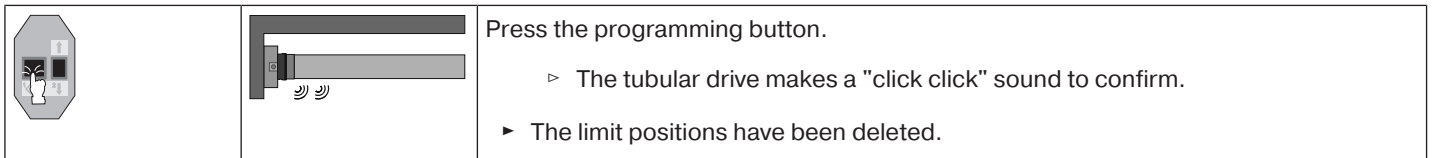

Deleting limit positions after installation

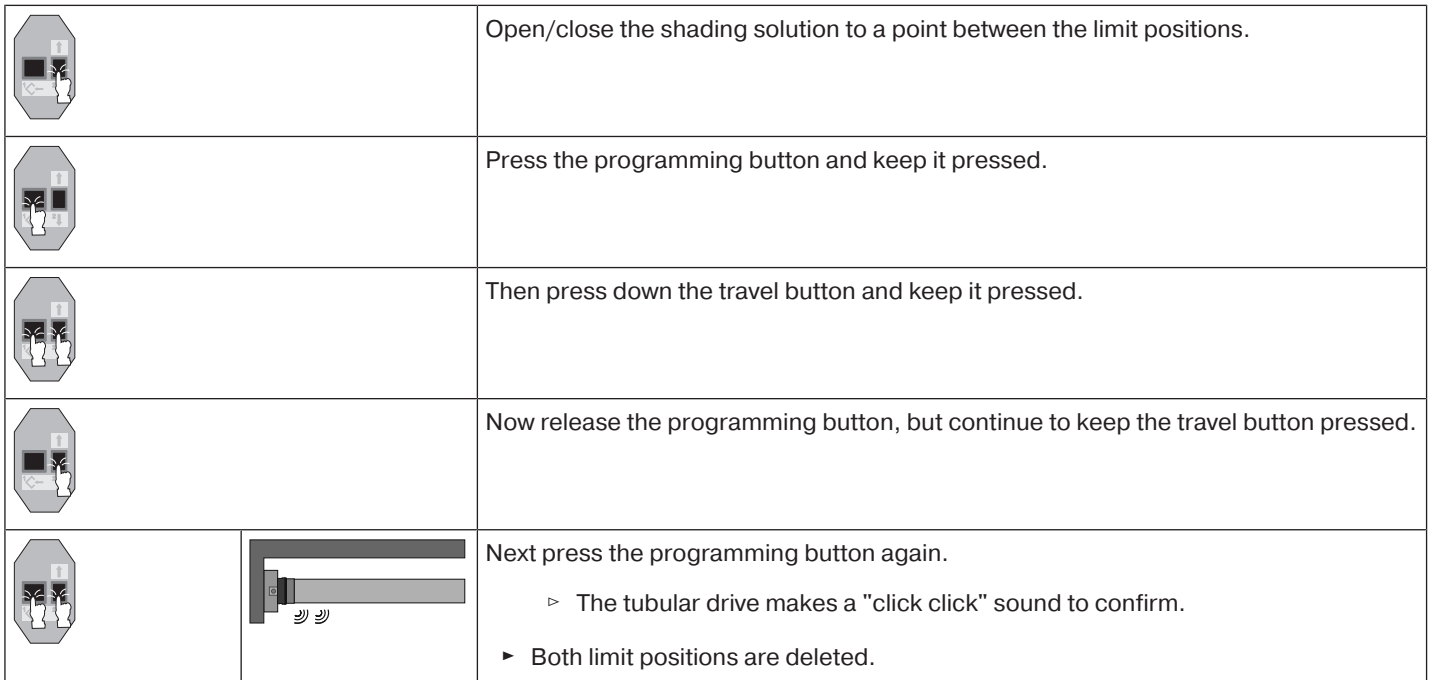

Information for the electrician

Tubular drives with electronic limit switching can be connected in parallel. The maximum switching contact load of the switching equipment (timer, relay control, switch, etc.) must be observed. To operate drives with electronic limit switching, only use switching elements (timers) that are **not** earthed via the drive. The outputs of the switching element must be potential-free in the neutral position.

Use external conductor L1 to control the up and down direction. Other devices or consumers (lamps, relays, etc.) must not be directly connected to the drive connecting cables. For this purpose, the drives and additional devices must be decoupled by relay controls.

When installing the drive, all-pole disconnection from the mains with a contact gap of at least 3 mm per pole must be provided (EN 60335).

Attention

Only use mechanically or electrically locked switching elements with a marked zero position! This also applies when drives with electronic and mechanical limit switching are used in the same system. The changeover time for switching the running direction must be at least 0.5 s. The switch and control must not execute simultaneous UP and DOWN commands. Protect the electrical connections from damp.

Once you have finished wiring everything to the control, ALWAYS check the right direction assignment of the drive to the control buttons UP and DOWN, EXTEND and RETRACT.

If the drive is to be operated with devices which contain sources of interference, the electrician must ensure suitable interference suppression for the relevant devices.

Disposal

This product is made of various materials which must be disposed of properly. Find out about the applicable regulations on recycling or disposal for this product in your country.

The packaging material must be disposed of properly.

Maintenance

These drives are maintenance-free.

Technical data dia. 45

Type	R12/17 C SE I1 R12/17 C SE T1	R20/17 C SE I1	R30/17 C SE I1	R40/17 C SE I1
Rated torque [Nm]	12	20	30	37
Output speed [rpm]	17	17	17	17
Limit switch range	64 revolutions			
Supply voltage	230 V AC / 50 Hz			
Connected load [W]	110	160	205	260
Rated current consumption [A]	0.50	0.75	0.90	1.15
Mode	S2 4 min			
Degree of protection	IP 44			
Min. tube inside diameter [mm]	47			
Emission sound pressure level [dB(A)]	≤ 70			



Technical data dia. 58

Type	L50/17 C SE I1	L70/17 C SE I1
Rated torque [Nm]	50	70
Output speed [rpm]	17	17
Limit switch range	64 revolutions	
Supply voltage	230 V AC / 50 Hz	
Connected load [W]	315	430
Rated current consumption [A]	1.40	1.90
Mode	S2 4 min	
Degree of protection	IP 44	
Min. tube inside diameter [mm]	60	
Emission sound pressure level [dB(A)]	≤ 70	

Type	L80/11 C SE I1	L80/17 C SE I1*	L100/11 C SE I1	L120/11 C SE I1
Rated torque [Nm]	80	80	100	120
Output speed [rpm]	11	17	11	11
Limit switch range	64 revolutions			
Supply voltage	230 V AC / 50 Hz			
Connected load [W]	310	470	354	435
Rated current consumption [A]	1.40	2.10	1.56	1.90
Mode	S2 4 min			
Degree of protection	IP 44			
Min. tube inside diameter [mm]	60			
Emission sound pressure level [dB(A)]	≤ 70			

*) This tubular drive is not yet available.

What to do if...?

Problem	Cause	Remedy
Tubular drive overruns the limit position or does not reach the set limit position.	Limit positions have been deleted (tubular drive clicks twice when switched on) or reset (tubular drive clicks once when switched on).	
	External devices are connected to the connecting cables of the tubular drive.	Check electrical installation; remove external devices; re-program limit positions.
	Due to long cable, L1 and N connection have been reversed.	Change around L1 and N (N = blue, L1 = black/brown); reset limit positions.
	Cloth torn off.	Repair system; delete limit positions, then re-program limit positions
Tubular drive stops arbitrarily; cannot be restarted in the same direction.	Tubular drive is overloaded.	Use a more powerful tubular drive.
	Sun protection system keeps sticking; too much friction.	Ensure that the sun protection system runs smoothly.
	A pre-used tubular drive is installed	Delete limit positions, then re-program limit positions
Tubular drive does not run in the right direction.	Tubular drive is overheated.	The tubular drive is operational again after a few minutes.
	Tubular drive is faulty and only ever runs for 1 sec.	Replace the tubular drive; carry out RESET with the programming button. No clicking sound (emergency program); tubular drive can be opened and closed for dismantling using the programming unit.
	Tubular drive switched off the last time it went in that direction because of an obstruction.	Clear and remove the obstruction and set the drive in the direction required.
	Electrical connection faulty.	Check the electrical connection.
	A short circuit caused by dampness.	Repair electrical installation; re-program limit positions.
Tubular drive only runs for approx. 5 secs.	Tubular drive is in error mode.	Reset the limit positions or replace the tubular drive.



Sample wiring diagram

i The assignment of the black and brown wires according to the direction of travel is dependant on how the drive is installed (mounted to the right or to the left).

Controlling one/several drive(s) via a single switch/button

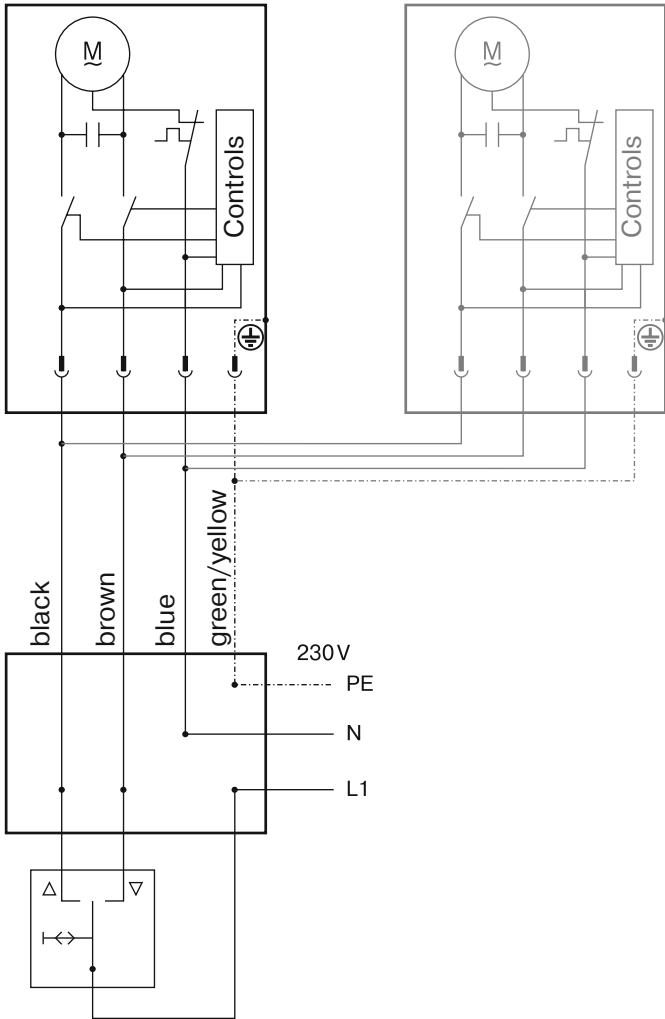

Declaration of conformity

BECKER-ANTRIEBE GMBH
Friedrich-Ebert-Str. 2-4
35764 Sinn, Germany



BECKER

- Original -

EU Declaration of Conformity

Document No./Month . Year: **K001/05.16**

We hereby declare that the following product series

Product designation: **Tubular motor**

Type designation: **R4/17.., R8/17.., R12/17.., R15/17.., R20/17.., R25/17.., R30/17.., R40/17.., R50/11.., R40/17.. (37 Nm), R7/17.., P9/16.., P5/30.., P5/20.., P13/9.., P5/16.., P4/16.., P3/30.., L44/14.., L50/11.., L50/17.., L60/11.., L60/17.., L70/17.., L80/11.., L80/17.., L100/11.., L120/11..**

Version: **C, M, HK, R, S, F, P, E, O, SMI, A0...Z9, mute, +**

From serial number: **from 161800001**

complies with the applicable regulations of the following Directives:

Directive 2006/42/EC (MD)

Directive 2014/30/EU (EMC)

Directive 2011/65/EU (RoHS)

Furthermore, the safety objectives of the **Low Voltage Directive 2014/35/EU** as per Appendix I No.1.5.1 of Directive 2006/42/EC have been met.

Applied standards:

EN 60335-1:2014

EN 60335-2-97:2015

EN 61000-6-1:2007

EN 61000-6-3:2011

EN 14202:2004

Authorised party for the compilation of the technical documentation:

Becker-Antriebe GmbH, Friedrich-Ebert-Str. 2-4, 35764 Sinn, Germany

This declaration of conformity was issued:

Sinn, 29.04.2016

Place, Date

Dipl.-Ing. Dieter Fuchs, Management

This declaration certifies compliance with the Directives cited but does not represent any assurance of characteristics.

The safety warnings in the supplied product documentation must be observed!



BECKER





BECKER